

MOKA 摩卡

工业机器人

Industrial Robot Series

Industrial
Robot
Series

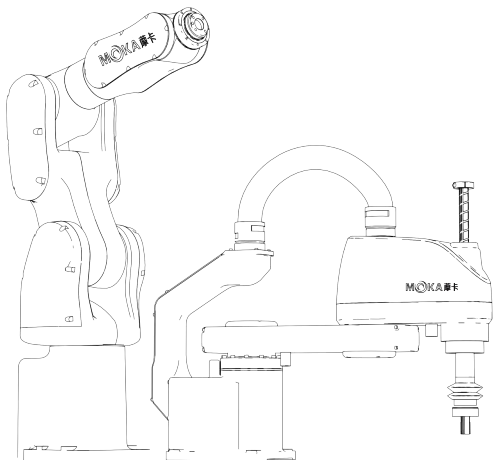

Higher Precision
更高精度



Higher Protection Level (IP67)
更高防护等级 (IP67)



Higher Speed
更高速度



Better Price Performance
更高性价比

V8.2

摩卡机器人全球化战略布局图

GLOBALIZATION MARKET LAYOUT

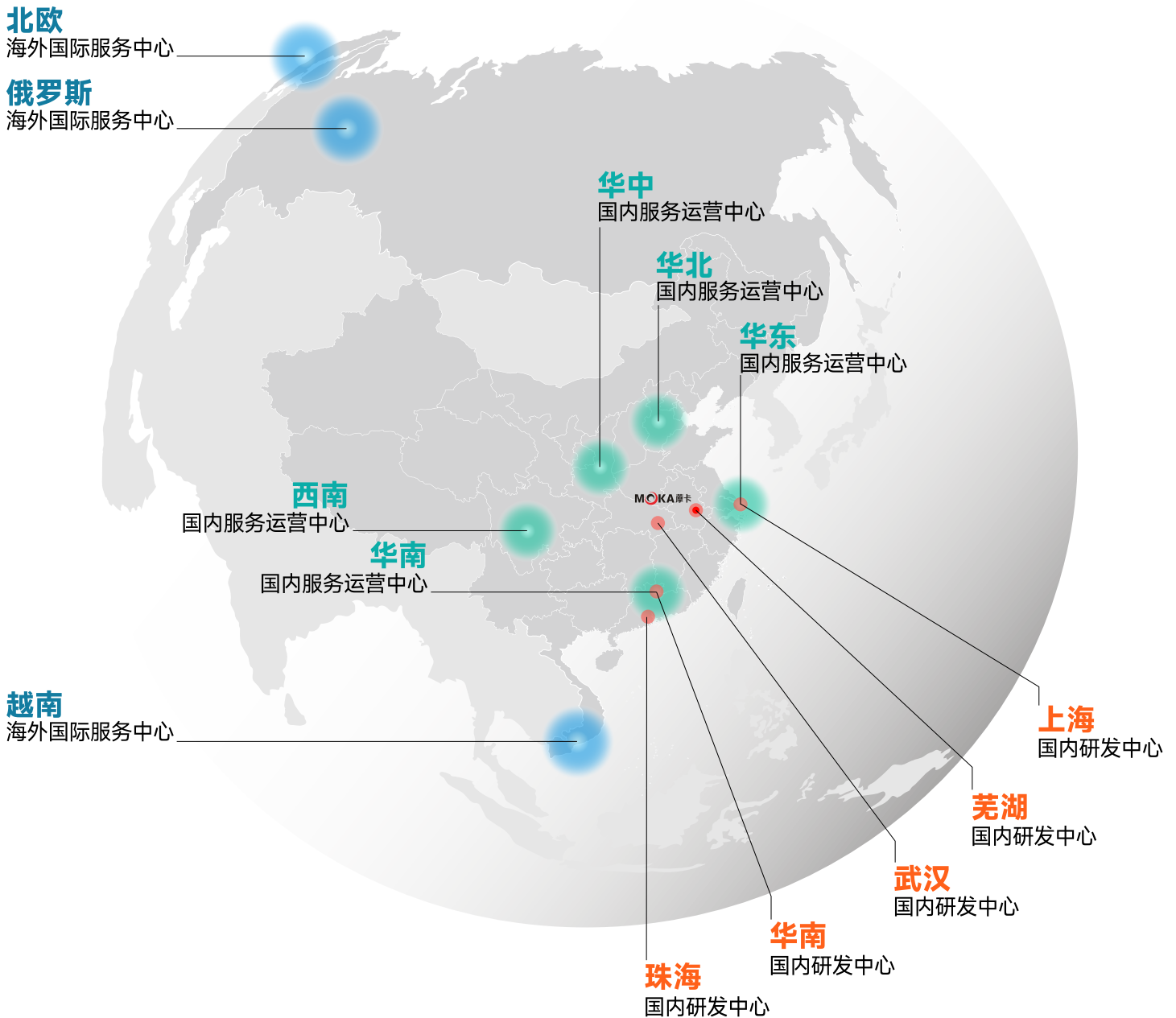



摩卡机器人科技有限公司是一家专业从事于工业机器人本体研发、生产制造、销售为一体的公司，目前拥有20余款系列工业机器人产品。公司依托10余年机器人研发技术优势和自身强大的细分市场高效定制能力，于2023年先后成立了“五大事业部”、“五大国内运营服务中心”和“三大海外国际技术服务中心”，在全面布局全球化战略的同时，深耕国内细分市场。摩卡机器人致力于将机器人自动化技术应用到各行各业，并以“引领新一代机器人自动化革命”为公司使命，始终践行“速度至上，精准为王”的产品理念，打造超高精度、超高速、超高性价比的机器人本体。

荣誉资质

Honorary qualifications

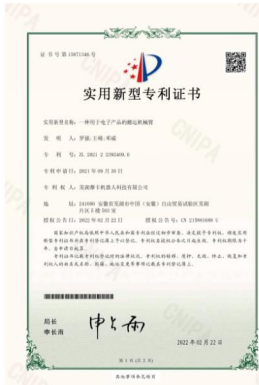
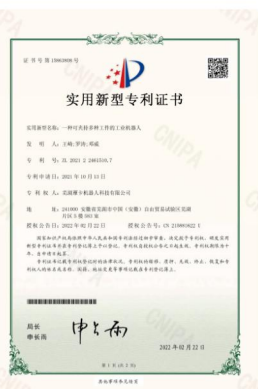



MB04SC-300



MB04SC-400

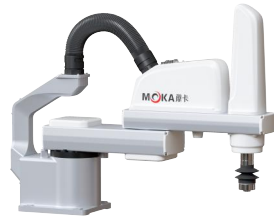

MB10SC-500



MB10SC-600



MB10SC-700



MB25SC-800



MB25SC-900



MB25SC-1000



MB04S-580



MB10S-740



MB10S-920



MB20-2100



MB35-1870



MB45-1870



MB180-3200



MB210-2650



MB280-2650



MR10C-1488



MR30C-1750



MR10W-1440-D



MR12-2010



MR12Z-1550



MR80E-2250



MR60E-2680



| | | | | | |
|--------|----------------|-------------|---------|-----------------------|----------------|
| 轴数 | Axis | 4轴 | 运动参数 | Moving range&speed | |
| 运动半径 | Motion radius | 400mm | 1轴S | J1+J2合成速度 7200mm/s | 运动范围±145° |
| 电源容量 | Power capacity | 1.5KVA | 2轴L | | 运动范围±145° |
| 有效载荷 | Payload | 额定1KG/最大4KG | 3轴U | 运动速度1200mm/s | 运动范围150mm |
| 重复定位精度 | Repeatability | ±0.01mm | 4轴R | 运动速度880°/s | 运动范围±360° |
| 机器人重量 | Robot mass | 15.5KG | 输入/输出信号 | Signals | 标配16进/16出24VDC |
| 内置气管 | Power capacity | Φ6 | 安装方式 | Install | 落地式 |

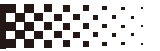

安装环境

| | | | | | |
|-------|------------------|----|---------------|-------------------|-------|
| 温度 | 0-45°C | 湿度 | 20~80%RH(无结露) | 无引火性、腐蚀性气体、液体、无溅水 | 少油、粉尘 |
| 振动加速度 | 4.9M/S2 (0.5G)以下 | 海拔 | 1000M以下 | 远离电磁源 | 远离磁场 |

控制柜参数

| | | |
|-----------|-------------------------|---------------------------------------|
| 外形尺寸 | Overall dimension | 420 (宽) * 450 (深) * 200 (高) mm (含突起物) |
| 概略质量 | Rough quality | 18.5KG |
| 冷却方式 | Cooling method | 直接冷却 |
| 电源规格 | Power specifications | 单相220V 50/60HZ |
| 接地 | Grounding | 工业接地 (接地电阻100Ω以下专用接地) |
| 输入输出信号 | Input/Output signal | 通用信号: 输入16, 输出16 (16进16出) |
| 位置控制方式 | Position control method | 串行通信方式EtherCAT.TCP/IP |
| 内存容量 | Memory capacity | JOB: 200000步, 10000机器人命令 (共200M) |
| LAN(上位连接) | LAN(Host link) | Ethercat (1个) TCP/IP (1个) |
| 控制方式 | Control mode | 软件伺服<位置控制> |
| 周围温度 | Ambient temperature | 通电时: 0~ + 45°C, 保管时: - 20~ + 60°C |
| 驱动单元 | Driver unit | AC伺服用伺服包 (共4轴) |
| 相对湿度 | Relative humidity | 10%~90% (不结露) |
| 振动 | Vibrate | 0.5G以下 |

| | | |
|-------|-----------------|--|
| 串口I/F | Serial port I/F | RS485 (一个) RS422 (一个) RS232 (一个) CAN接口 (一个) USB接口 (一个) |
| 海拔 | Altitude | 海拔1000m以下, 超过1000m, 每增加100m最大周围温度降低1%, 最高可在2000m使用。 |
| 其它 | Other | 无粉尘、切屑液 (含冷却液)、有机溶液、油烟、水、盐分、药品、防锈油、无强微波、紫外线、X射线、放射线照射 |

示教编程器规格

| | | |
|------|--------------------|---------------------------------------|
| 外形尺寸 | Overall dimensions | 280 (宽) * 220 (深) * 120 (高) mm (含突起物) |
| 毛重 | gross weight | 0.6KG |
| 材质 | material quality | 强化塑料 |
| 显示屏 | display screen | 8英寸彩色LED、触摸屏640*480像素 |
| 防护等级 | protection grade | IP54 |
| 电缆长度 | Cable Length | 标配: 5m; 选配: 15m |

| | | |
|-----|-------------|---|
| 操作机 | manipulator | 选择键、轴操作键、数值/应用键、带钥匙的切换模式键/ (示教模式、再现模式、远程模式)、急停键、始能键、USB端口1个 |
|-----|-------------|---|



安全注意

使用前请熟读说明书及附属文件等,正确使用。

·此目录记载的产品为MB04SC-400

如 MB04SC-400发生的故障以及错误及错误操作直接威胁到人身安全,或被使用于危害人体安全的用途时请与我们联系,我们将作出改善。

·图解为意向图。

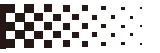

最大载荷

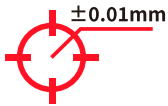

重复定位精度



动作范围

外形尺寸及动作范围

P点运动范围

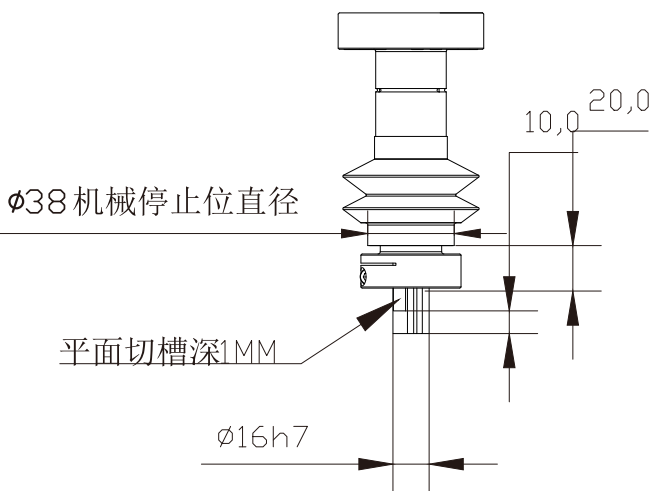
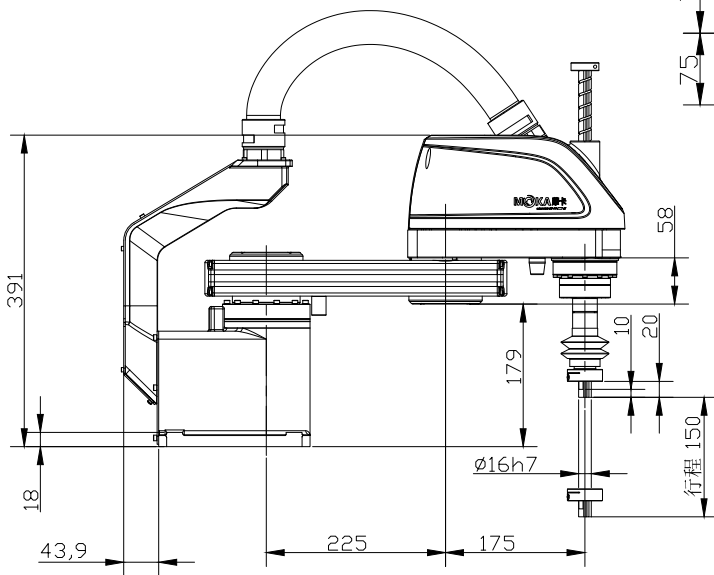
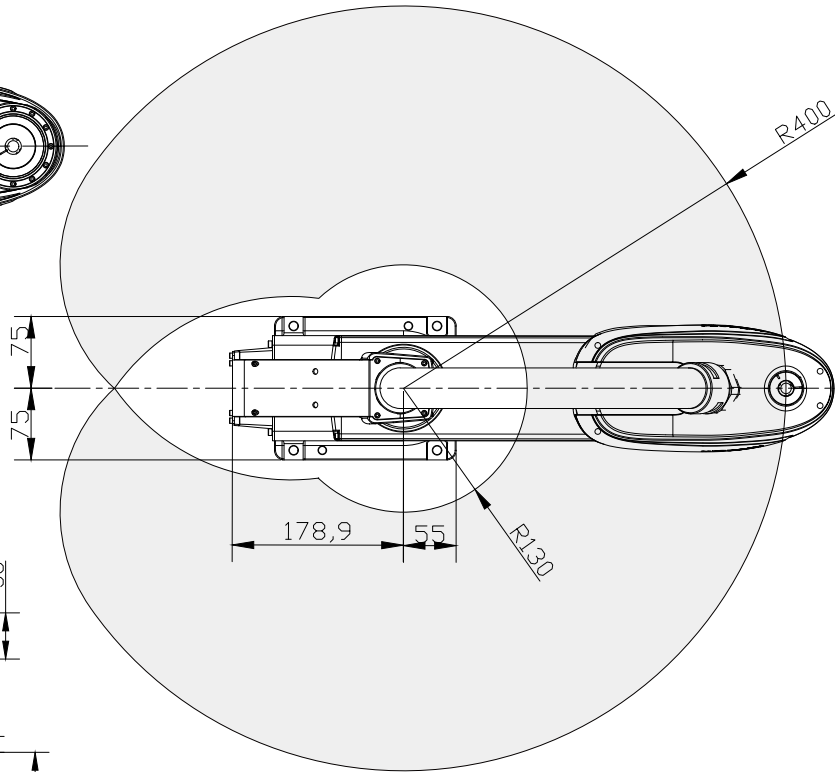
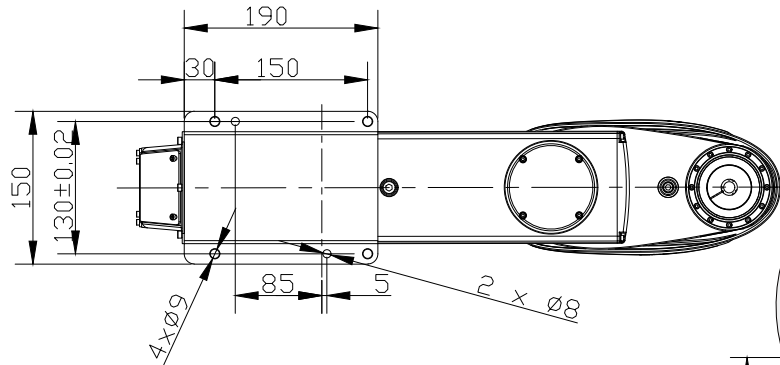

末端法兰安装尺寸

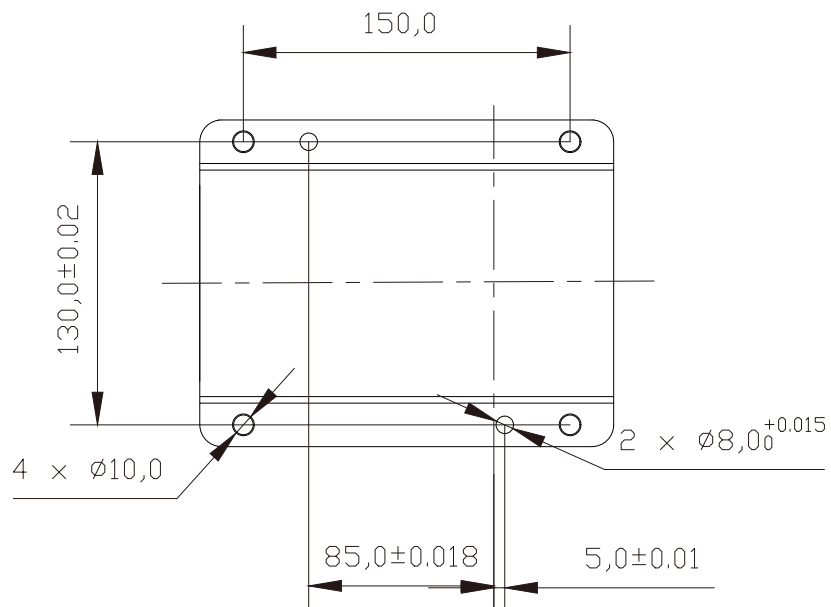

底座安装尺寸

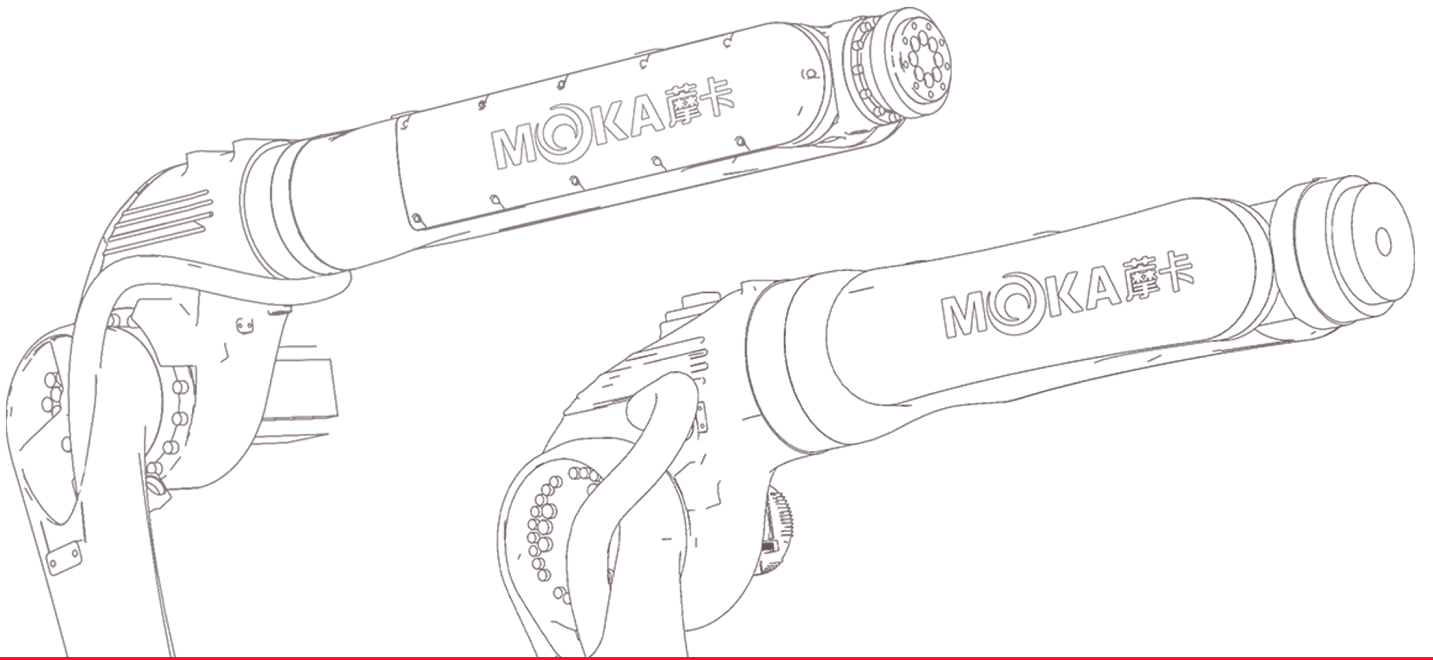

MOKA 摩卡

引领新一代机器人自动化革命



芜湖摩卡机器人科技有限公司

WUHU MOKA ROBOT TECHNOLOGY CO.,LTD

地址:安徽省芜湖市鸠江区纬四路19号

NO.19,Wei 4th Road,JiuJiang District,Wuhu City,Anhui Province

官方网址:www.moka-robot.com

企业邮箱:moka@moka-robot.com

全国热线:400-800-5282